

KOHLER KDI 1903/2504 ENGINE

COMAP ILLANO2 AMF5

A1

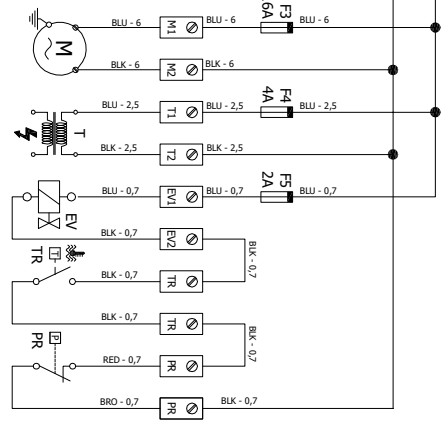

TERMINAL SHROUDS AND SELECTORS:

- + : (+) BATTERY
- : (-) BATTERY
- GND : GROUND
- M1 : PRESSURE PUMP
- M2 : PRESSURE PUMP
- T1 : HEATER TRANSFORMER
- T2 : HEATER TRANSFORMER
- EV1 : ELECTROVALVE
- EV2 : ELECTROVALVE
- PR1 : PRESOSTATE
- PR2 : PRESOSTATE
- TR1 : WATER TEMPERATURE SELECTOR
- TR2 : WATER TEMPERATURE SELECTOR
- S0 : EMERGENCY STOP
- S1 : HOT WATER SELECTOR

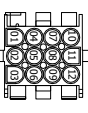

MATE'N'LOOK BOARD
SIDE
Male pins Front view

- 1-01 : AUX. FUEL PUMP (GRA - 2,5mm²)
- 1-03 : ALTERNATOR (LE) (GRE - 0,7mm²)
- 1-04 : START (BLK - 2,5mm²)
- 1-05 : STOP (GRA - 0,7mm²)
- 1-06 : COOLANT TEMP. SENSOR (ROS - 0,7mm²)
- 1-07 : OIL PRESSURE CONTACT (WHI - 0,7mm²)
- 1-08 : FUEL LEVEL SENSOR (RED/BLU - 0,7mm²)
- 1-09 : WATER LEVEL CONTACT (ORA - 0,7mm²)
- 1-11 : AIR FILTER CONTACT (ORA - 0,7mm²)
- 1-12 : ADV. INJECTION ACTUATOR (BLK/WHI - 0,7mm²)
- 2-01 : PICK-UP (BRO - 0,5mm²)
- 2-02 : PICK-UP (WHI - 0,5mm²)

IN2 AMF5+KDI 1903_2504 HWM_20251031		Fecha ultima modificacion		31/10/2025		ILLANOZ AMF5 + KDI 1903	
Determinacion de plano en PDF				Adjuntar a planos			
No. de Proyecto		Fecha		Nombre		Descripción	
02/04-2025		02/04-2025		L.A. CARRO		HOT WATER HIGH PRESSURE CLEANER	
ESCALA:		S/E		LITERS		DENOMINACION DWG E82 INTERLORVE	

